

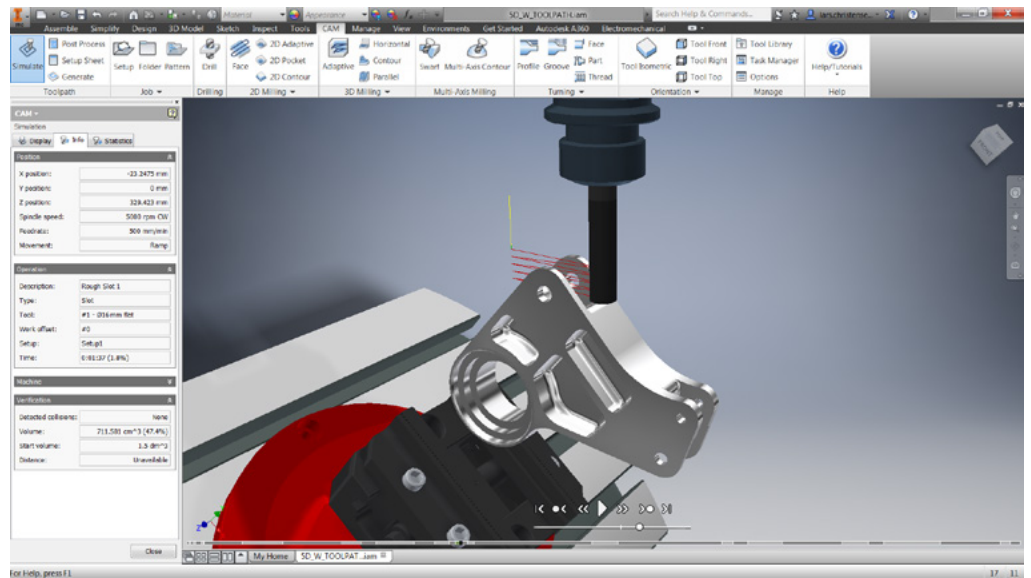

# Take control of your manufacturing

Achieve higher productivity, reduced costs, and shorter time to market using Inventor HSM

Autodesk® Inventor HSM™ 2016 CAD/CAM software helps CNC programmers, designers, and engineers rapidly produce machined parts designed in virtually any CAD system. Whether you are working with multiple CAD formats or starting from pencil sketches, Inventor HSM helps you get up to speed and become productive within minutes using a truly integrated design to manufacturing solution. In addition to all the standard toolpath strategies for milling and turning operations, Inventor HSM includes advanced features such as adaptive clearing, integrated simulation and verification tools, and a powerful post processor system.



## Adaptive Clearing

Adaptive clearing is an advanced roughing strategy that sets the bar for efficient, high-volume material removal. Using constant tool engagement and optimized cutter paths, Inventor HSM reduces roughing time by a factor of 4 or more compared to conventional roughing, and increases tool life by as much as a factor of 10, depending on material hardness. Enhanced multi-core support and improved linking make adaptive clearing the most advanced adaptive roughing technology to date.

## AnyCAD

AnyCAD is a CAD interoperability solution included in Autodesk® Inventor® that reduces the need to maintain multiple CAD systems and eliminates manual file translation and updates. Parts and assemblies can be selectively imported into Inventor from virtually any CAD system while keeping associativity. Design changes in the source CAD system get automatically updated in downstream data such as drawings and toolpaths, saving you valuable time and resources and minimizing costly translation errors.

## Modern architecture

Inventor HSM is designed to take advantage of latest workstation technologies to help you achieve superior performance, especially when working on large or complex designs.

Multiprocessor/multi-core support dramatically speeds up toolpath generation on supported hardware. Distributed CAM server helps maximize use of your computing power by utilizing idle PCs on the local network to reduce toolpath calculation time.

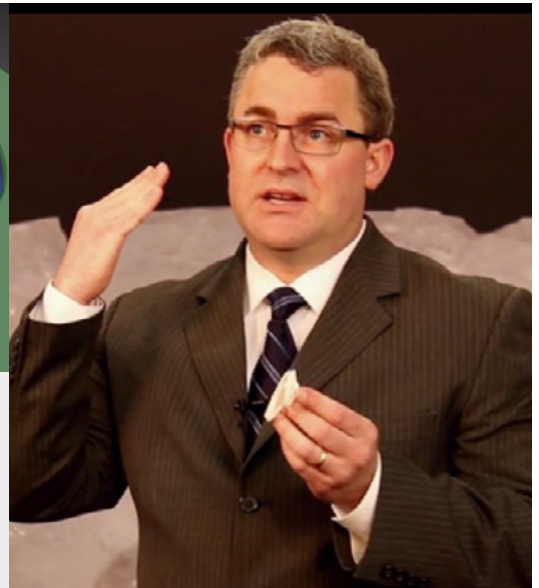
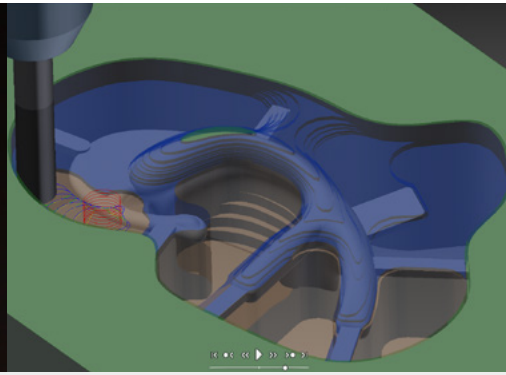

“As a medical device company making cranial implants, we rely on Inventor HSM to give us the ability to make these products in a very predictable and linear method so we can depend on the results and produce the parts that we want.”

— **Aaron M. Noble**,  
CEO of Poriferous, LLC

### Stock simulation

Integrated stock simulation in Inventor HSM enables users to see stock being removed and to automatically check for shaft and clamp/fixture collisions. Users can color the surface by tool number to inspect the resulting stock model, and they can slice the model to inspect different sections.

The target part comparison feature can be used to highlight rest and gouge areas with different colors. 3+2 machining is supported and multiple toolpaths can be verified in a single operation.

### Toolpath simulation

After generating a toolpath, users can easily inspect results with the integrated backplot and inspection tool. Controls include simulation speed and direction, visibility and translucency of tool, shaft, tool holder, and coloring of rapid moves, lead moves, and cutting moves.

Use the advanced analysis tool to measure distances, or dynamically view all vital information about tools, and details such as feed/speed and estimated machining time. 3+2 machining is supported, and you can inspect multiple toolpaths in a single operation.

### Tool lists and setup sheets

Tool lists, setup sheets and other production documents are automatically generated and can be exported in a variety of formats including HTML, XML, Microsoft® Excel®, and Microsoft® Word.

Production documents are generated by the advanced Inventor HSM post processor with high degree of flexibility and user customization.

### Inventor HSM Edit

Inventor HSM includes Inventor HSM Edit for inspecting and manually editing NC program files. Inventor HSM Edit provides a number of CNC code-specific functions, including line numbering/renumbering, XYZ range finder, and file compare. Inventor HSM Edit features a DNC link for reliable RS-232 communications with a variety of CNC controls.

### Post processors

No CAM system is complete without a post processor that produces ready-to-run code tailored to your machine, control, and programming style. Inventor HSM uses a flexible, open, and exceptionally fast post processor to perform this critical task.

JavaScript programming language, enabling on-site customization by customers and resellers, resulting in a significant reduction in post development time.

Inventor HSM comes with numerous generic post processor configurations. Each post processor is customizable to the user's specific requirements. Our aim is to produce 100 percent ready-to-run code for your machine.

- Fanuc
- Heidenhain
- Haas
- Hurco
- MillPlus
- Okuma
- Siemens
- Yasnac
- and many more....

# Autodesk Inventor - professional grade CAD system

Autodesk Inventor helps you to complete your design quickly, easily, and with flexibility by combining parametric, freeform, and direct editing tools.

## Design and document products digitally

Autodesk Inventor provides an intuitive parametric design environment for developing initial concept sketches and kinematic models of parts and assemblies. Inventor software automates the advanced geometry creation of intelligent components, such as plastic parts, steel frames, rotating machinery, tube and pipe runs, and electrical cable and wire harnesses. Inventor also helps reduce the geometry burden so you can rapidly build and refine digital prototypes that validate design functions and help minimize manufacturing costs.

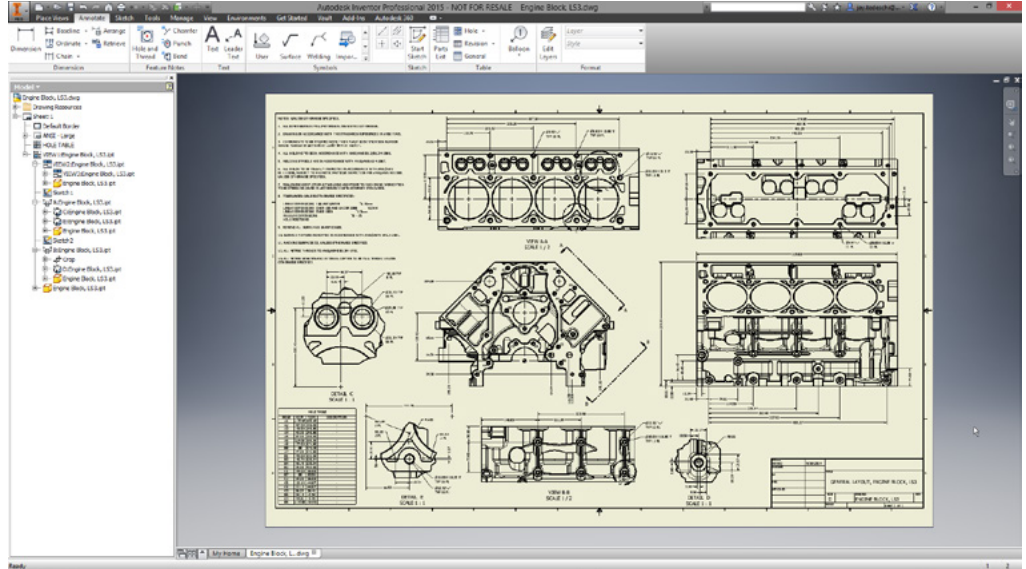

Full associativity between the model and machining operations

Seamless workflows

Engineering Change Order

Manufacturing improvements

## Seamless workflow experience from design to manufacturing

AnyCAD in Inventor enables users to maintain full associativity between the non-native model and machining operations, so any changes to the model are automatically reflected in the toolpath. Late design changes no longer mean missing delivery deadlines or introducing last-minute programming errors.

### Key advantages of Autodesk Inventor:

- Instant association with the CAD model
- No data translation errors
- Fewer files to manage
- Superior CAD tools
- Lower training costs
- Superior machining flexibility

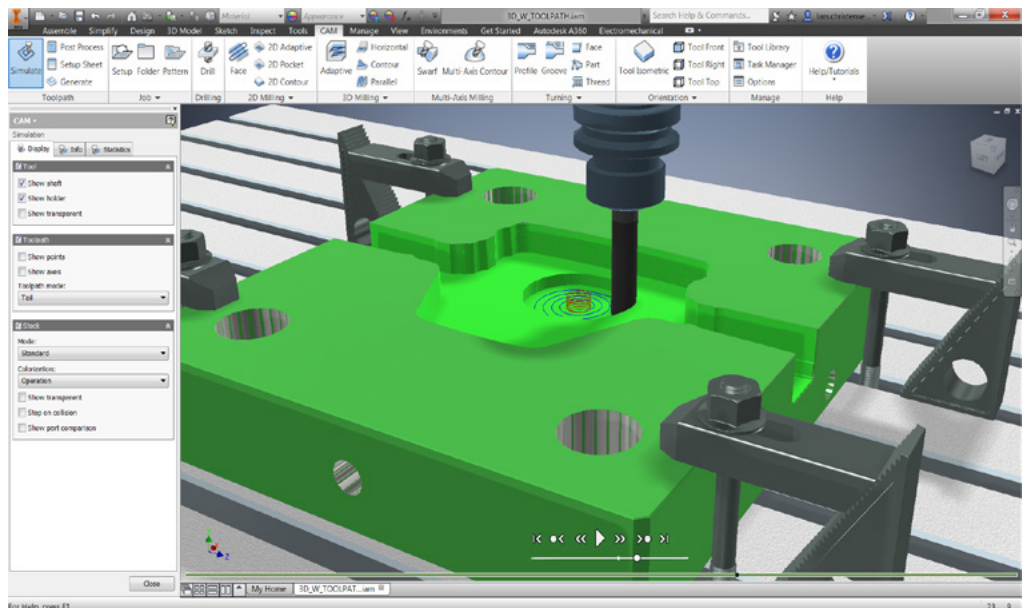

## 2D / 2.5D milling

2D machining can range from the very simple to the very complex. Inventor HSM solutions include the tools you need for precise control over all aspects of 2D machining, including lead in/out and transitions between passes.

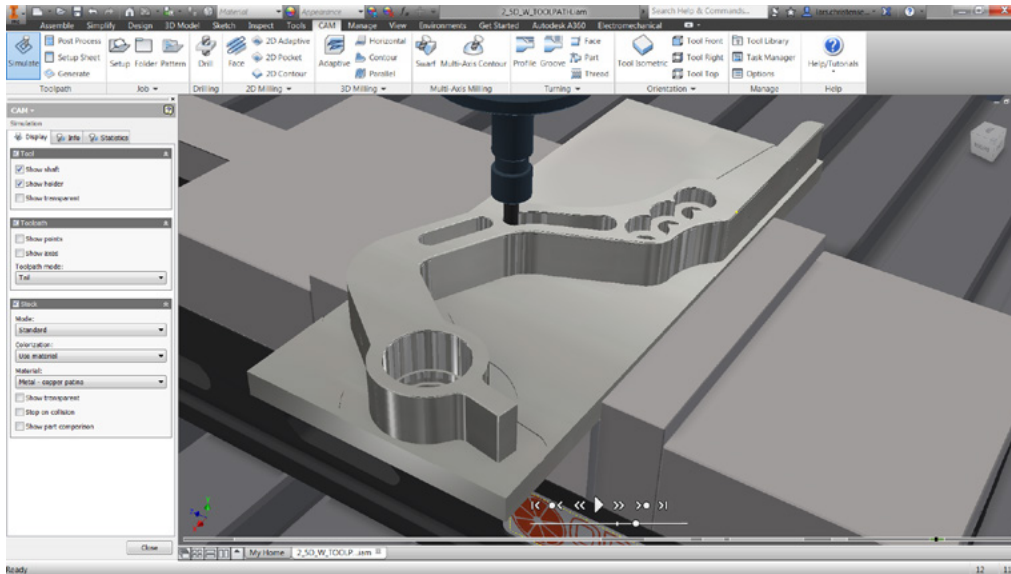

### Contouring

Easily machine 2D and 3D contours. Control lead-in and lead-out, and choose multiple roughing and finishing passes and multiple depth cuts for any contour. Machine open and closed contours without creating additional geometry, and eliminate sharp motion with corner smoothing.

### Adaptive clearing

Pocket toolpaths machine closed areas with and without islands. Entry can be selected anywhere on the model and set for plunge, ramp, or at a predrilled position. The special high-speed option creates smooth toolpaths that support constant tool engagement, significantly higher feedrates, and reduced machining time and tool life.

### Drilling and hole making

Inventor HSM includes powerful tools for generating drilling, counterboring, and tapping operations. All operations are optimized to minimize tool travel and overall cycle time. Both standard and customized cycles are supported for all point-to-point operations, including spot-drilling, deep drilling with chip break, and boring cycles.

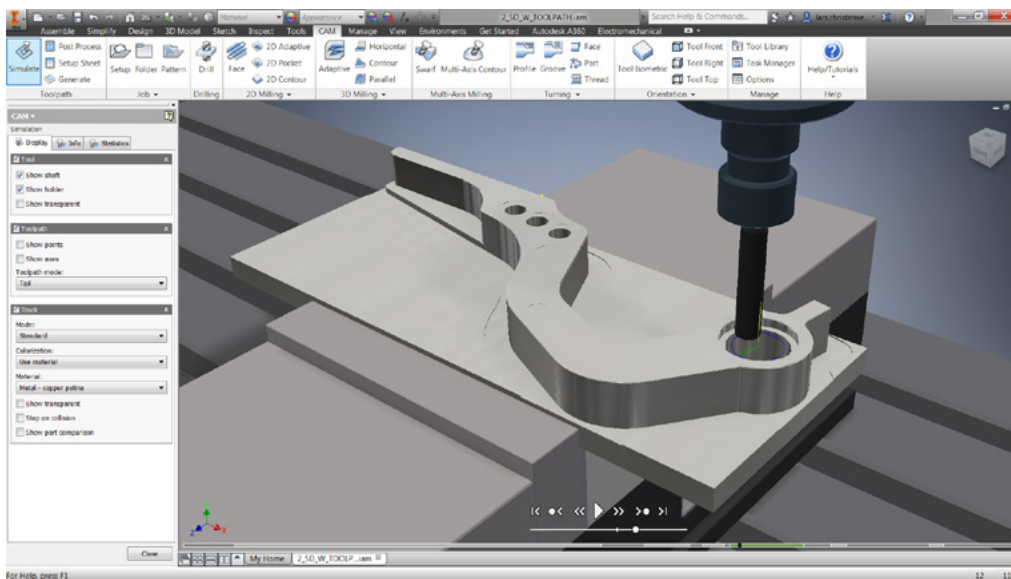

Simply powerful  
2D machining

Complete control over every aspect of the toolpath

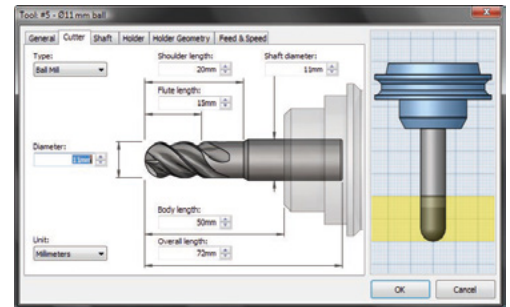
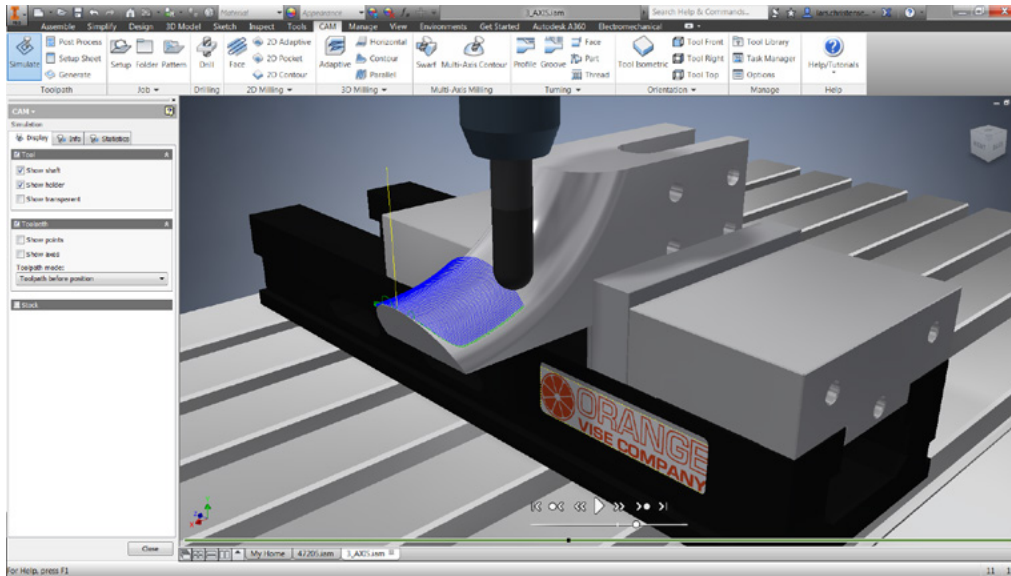

Define all relevant tool parameters in the Inventor tool library

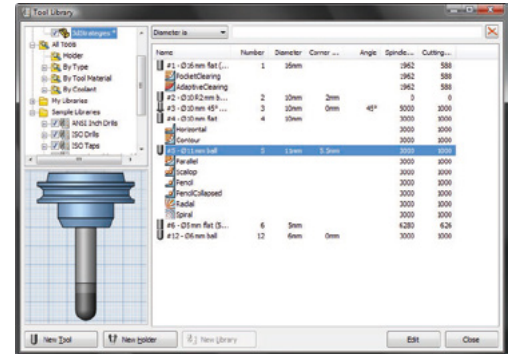

Manage tools and holders with the Inventor tool library

## 3D milling

HSM stands for high-speed machining. The main goal of high-speed machining is minimizing run time. Other factors, including surface quality and tool life, are also important.

Inventor HSM toolpaths are optimized to address all these factors by reducing cycle times, improving surface quality, and extending tool life.

High speed machining for everybody

### Best-in-class 3D strategies

Inventor HSM strives to generate the shortest and smoothest toolpaths possible, resulting in reduced machining time, improved surface quality, less tool wear, and extended machine tool life.

In addition to the traditional pocket clearing strategy, Inventor HSM features the innovative adaptive clearing strategy that reduces roughing time by a factor of 4 or more compared to conventional roughing, and increases tool life by as much as a factor of 10, depending on material hardness.

Finish paths follow part faces to create the final part shape. Many machining strategies are available to suit the part topology. Inventor HSM provides superior finish machining technologies that incorporate smooth/tangent lead in/out moves to keep the tool moving in a smooth motion, helping to reduce machine wear and tool marks.

- Pocket
- Adaptive clearing
- Contour
- Parallel
- Pencil
- Scallop/constant stepover
- Spiral
- Radial
- Horizontal
- 3+2 machining

### Tool library

Tool information can be specified directly using the Inventor HSM tool library, or imported from third-party tool databases. Production documents, including tool lists, are automatically generated and can be exported in a number of different formats including HTML, XML, Microsoft® Excel® and Microsoft® Word.

### 3+2 machining

All 2D and 3D strategies support 3+2 machining (5-axis positioning) by rotating the part or the head of the machine tool through a combination of A, B, or C axis motions. Create 3+2 operations by simply selecting a work plane for the operation. Inventor HSM takes care of the rest by finding the most efficient rotations to orient the part. Once parts are positioned, all machining strategies are available. Tools and holders are gouge protected for all strategies that normally support this feature.

# Multi-axis milling

Inventor HSM integrates multi-axis simultaneous machining into its milling and mill/turn environment using the same intuitive approach to toolpath programming found in our 2D/3D machining strategies. Multi-axis machining has traditionally been regarded as an advanced technology best suited to the aerospace and automotive industry.

Inventor HSM improves production machining by breaking down this barrier and making multi-axis machining accessible to everybody.

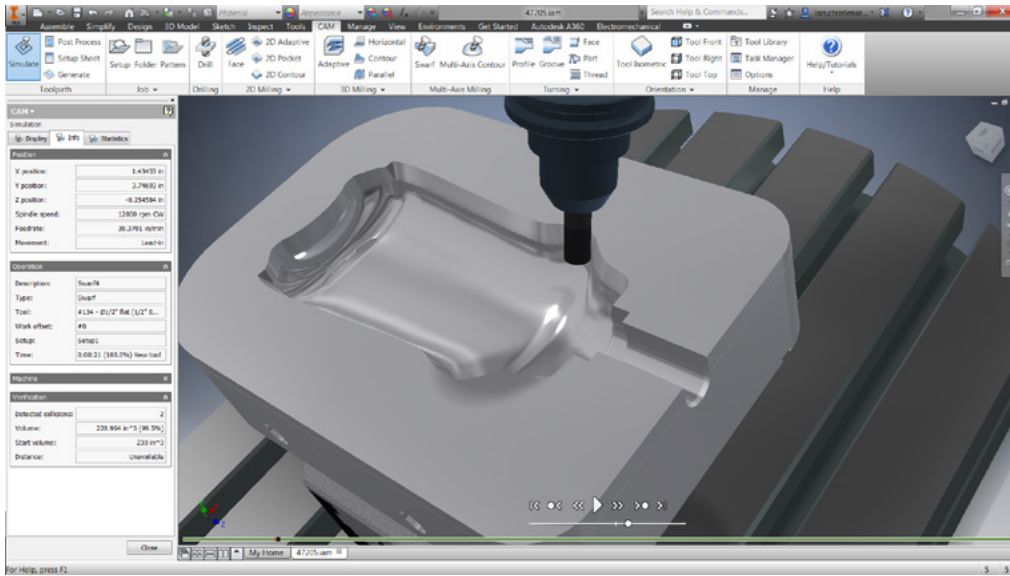

- Swarf
- Multi-axis contour
- 3D toolpath tilting

## 3D toolpath tilting

Many parts contain deep cavity areas and small radii that need to be machined with small-diameter tools. With Inventor HSM these areas can be machined effectively by automatically tilting the tool and holder away from the workpiece, enabling the use of shorter tools to reduce vibration and deflection.

## Multi-axis simultaneous machining

Inventor HSM offers a number of multi-axis strategies that provide the programmer with productive solutions for easily creating highly efficient multi-axis toolpaths with advanced collision control for the most complex 3D models.

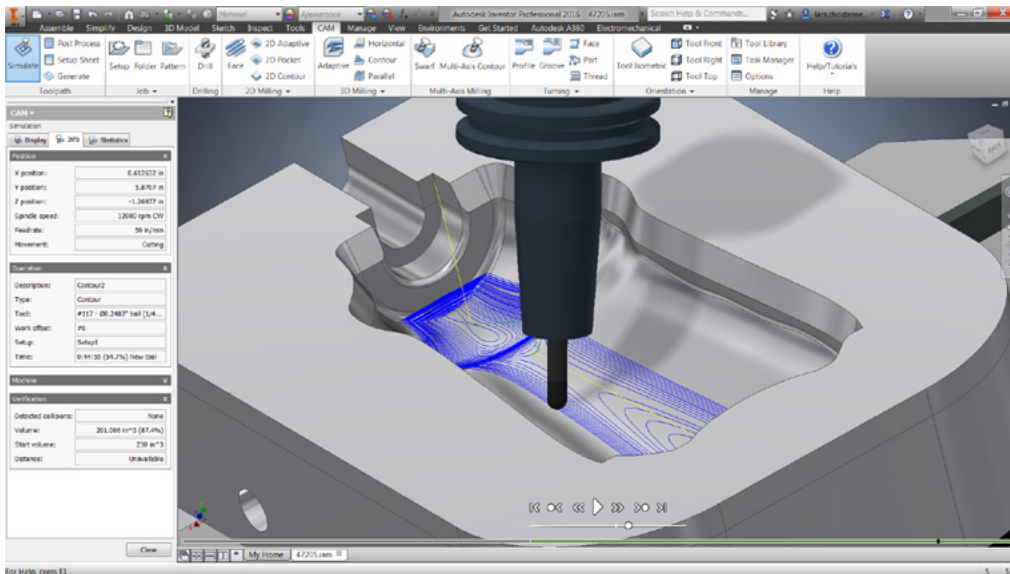

# Turning

Whether you are looking for a CAM system to help you improve your productivity with traditional turning operations like roughing, grooving, or finishing – or you want to start taking full advantage of your multi-axis machine tools, Inventor HSM offers an intuitive approach to creating high-quality turning toolpaths.

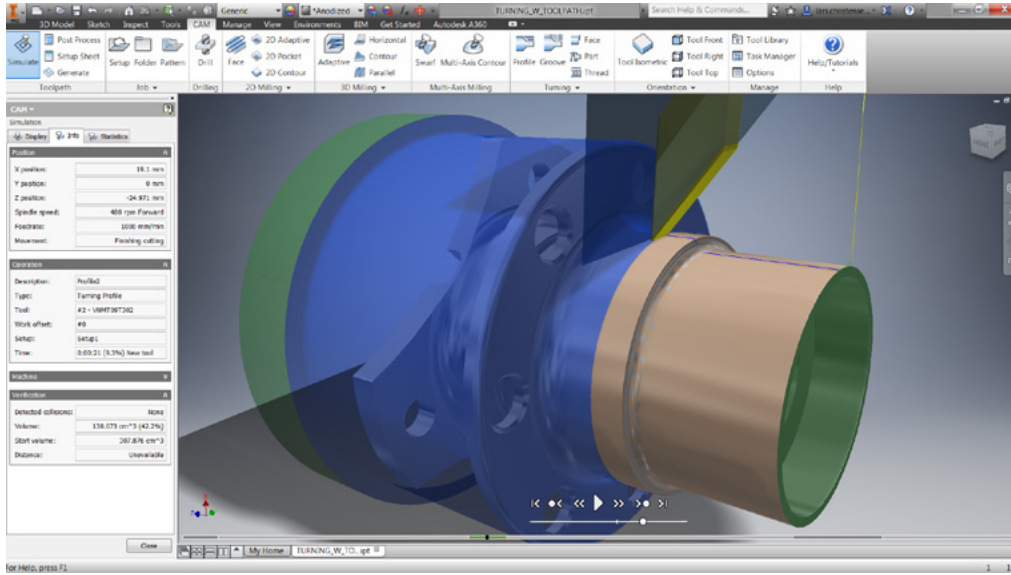

- Facing
- Roughing
- Profiling
- Grooving
- Drilling
- Parting

## Twin-turret, sub-spindle and mill/turn

Inventor HSM supports programming twin-turret and twin-spindle lathes using all traditional turning operations. Mill/turn operations are supported when combined with the Inventor HSM 2D or 3D milling option.

## Traditional turning

Inventor HSM features all the traditional turning toolpaths, including facing, roughing, grooving, threading, drilling, and profiling. For drilling and hole making, choose between pre-programmed machining cycles and canned cycles, or use a combination of both.

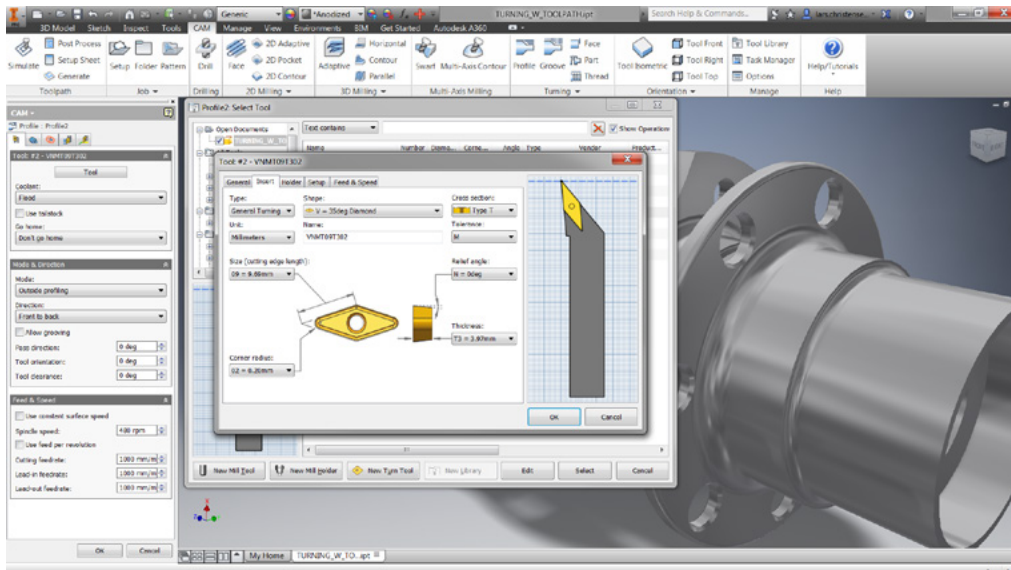

# Professional machining made easy and accessible

Choose the right CAD/CAM solution for your machining needs and take advantage of flexible pricing options. Download the free 2.5D solution, or a 30-day trial of our advanced 3D and 5-axis solutions today.

Download your Inventor HSM CAD/CAM solution today or contact a reseller near you.

Visit: [cam.autodesk.com/inventor-hsm](http://cam.autodesk.com/inventor-hsm)

 AUTODESK®  
INVENTOR HSM EXPRESS™

**Free\* Professional 2.5 axis milling  
and drilling applications**

*Requires Autodesk® Inventor®*

 AUTODESK®  
INVENTOR HSM™

**2.5D, advanced 3D and 3+2 milling  
and turning applications**

 AUTODESK®  
INVENTOR HSM™ PRO

**2.5D, advanced 3D and 5-Axis milling,  
and turning applications**

## CNC Programmers

Inventor HSM CAD/CAM solutions deliver unbeatable performance and quality that puts you in control of your CNC programming operations.

## Designers & Engineers

Whether you are prototyping or producing finished parts, Inventor HSM provides a seamless integrated CAD/CAM experience that puts you in control of the design to manufacturing workflow.

## Subscribe to Autodesk

Subscribing to Autodesk products is the most flexible and cost-effective way to access the latest design, engineering, and entertainment software and services you need to help grow your business. Autodesk subscribers get access to the latest releases and product enhancements, flexible licensing rights, cloud services, and technical support. Learn more at [www.autodesk.com/subscription](http://www.autodesk.com/subscription)

- Increased speeds and feeds with Adaptive Clearing
- Advanced simulation and verification tools
- Includes posts for industry standard machines
- Product updates for the duration of license
- Expert technical support

\*Free Autodesk software licenses and/or cloud-based services are subject to acceptance of and compliance with the terms and conditions of the license agreement or terms of service, as applicable, that accompany such software or cloud-based services.

\*\* Actual retail price is determined by your reseller. Annual Desktop Subscription plans may not be available through all resellers or in all countries.